

McHale



CENTRE
DELIVERY
RAKE



WWW.MCHALE.NET

The Professional Choice

MCHALE CENTRE DELIVERY RAKE RANGE

Over the last decade the McHale range of centre delivery rakes have been operating in six continents in some of the world's most difficult conditions.

McHale centre delivery rakes have developed a reputation for providing;

- HIGH OUTPUT
- EXCELLENT RELIABILITY
- OPERATOR COMFORT
- TOP RESALE VALUE
- LOW MAINTENANCE



CONTENTS

Introduction	1 - 4
R CENTRE DELIVERY RAKE RANGE	5
R62-72	6
R68-78	7
R80-90	8
Standard Features	9 - 10
Headstock / Driveline	13
Various Adjustments	14
Rotors & Tines	15 - 16
Steering & Transport	17
TECHNICAL TABLE	18



A FAMILY BUSINESS WITH A GLOBAL PRESENCE



*McHale was founded by Padraic and Martin McHale in the mid 1980s in the west of Ireland and since then has transformed into a **GLOBAL LEADER IN THE MANUFACTURE OF GRASSLAND EQUIPMENT.***

In 1976, Padraic established a farm machinery retail outlet and was later joined in this endeavour by his younger brother Martin. The manufacturing company subsequently evolved from this dealership which is still in existence today.

From the start, Padraic looked after product design and manufacturing while Martin looked after sales and marketing. Although the business has grown substantially since, both brothers are still actively involved in the business and still manage these areas.

Following on from producing blockcutters and a range of slurry pumping equipment, in 1987, McHale manufactured its first round bale wrapper. Martin then developed a dealer and importer network which has expanded to 55 countries around the world.

Over 90% of McHale machines produced are destined for the export market and many of these dealers and importers have been working with McHale for over 30 years.

McHale now produce a wide range of products with a particular focus on grassland machinery. The McHale product range now incorporates:

- **Mowers**
- **Tedders**
- **Rakes**
- **Integrated Baler Wrappers**
- **Fixed Chamber Balers**
- **Variable Chamber Balers**
- **Round Bale Wrappers**
- **Square Bale Wrappers**
- **Straw Blowers & Silage Feeders**
- **Bale Handling & Splitting Equipment**

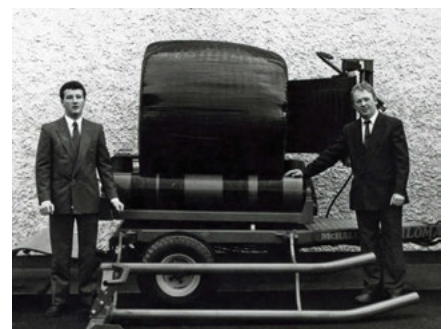

Padraic and Martin McHale
in 1990 (above) & 2019 (below)



Global Manufacturing



Today McHale operate two advanced manufacturing facilities. **Both factories utilise the latest in laser, CNC and robotic technologies.** All products are coated using advanced E-Coat & Powder systems.

As the product is built on the assembly lines, rigorous quality checks are conducted. Every complete machine is run, calibrated and tested before being exported to one of over 55 countries around the world.



Research & Development



The Research & Development department was established in 1994 and is still run by Padraic who has built a world class team of engineers around him.

All machines go through a **rigorous 3-year product development & testing cycle** before being launched. During the design and development stage all machines go through comprehensive testing with end users in various parts of the world.

Today, **over 10% of the workforce** are involved in new product development.

Product Support



Our specially **trained team of service engineers** are on hand to help in a quick and precise manner in order to provide the solutions you and your business need.

We also empower the service engineers of our dealers and importers with theoretical and practical training to ensure you receive **high-quality expertise and care** for you, your machine and your business. Qualified and equipped with the necessary knowledge and tools, our aim is to keep your business going at all times.

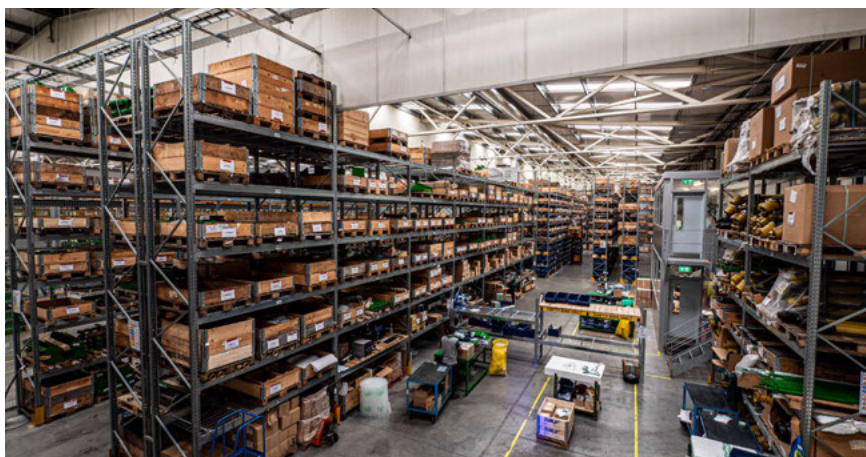
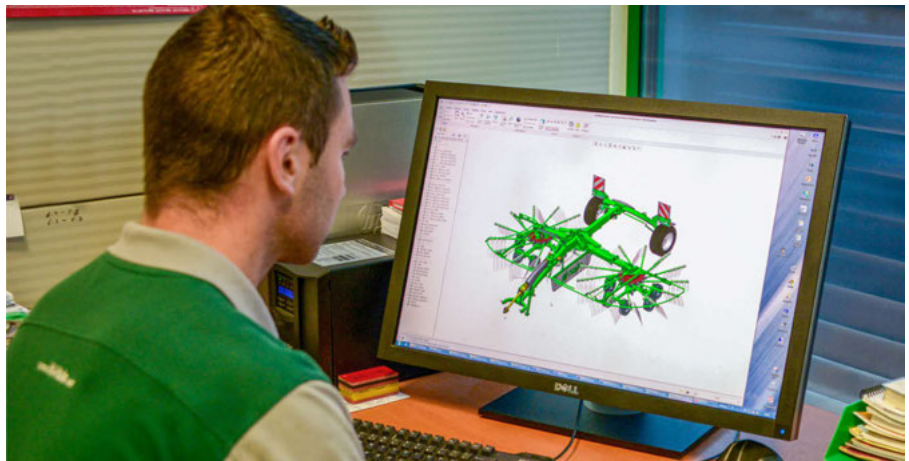

McHale Parts Distribution



With all parts in stock for McHale machines, our aim is to **supply original parts and components** that are specifically suited to your machine.

McHale stock a wide range of parts for machines produced up to 30 years ago as well as parts for the latest products in the range. These **parts are precisely manufactured** in order to meet the highest standards of performance and reliability.

THREE MODELS A RANGE TO MEET YOUR NEEDS

The McHale Centre Delivery Rake Range has been designed with the demands of today's **FARMER AND CONTRACTOR IN MIND**. This common sense approach to design ensures that each machine's operation is **KEPT SIMPLE AND USER FRIENDLY**.

Farmers and contractors all over the world are under pressure to reduce costs and increase output. On-going development of farming techniques has led to the need for thoroughly reliable, specialised machinery to meet these demands.

The McHale range of Centre Delivery Rakes have been operating across the globe, in some of the world's most difficult conditions and have developed an award winning reputation for delivering an ideal swath for maximum baling and harvesting output.

The McHale R Centre Delivery Rake Range consists of **3 models**;

ER 62-72 (6.2m - 7.2m)

ER 68-78 (6.8m - 7.8m)

ER 80-90 (8.0m - 9.0m)



The **MCHALE R62-72 CENTRE DELIVERY RAKE** is a compact rake with a working width ranging from 6.2m (20' 4") to 7.2m (23' 7"). This compact rake has the ability to combine multiple rows or alternatively can form a row from grass which has been left fully spread after mowing.

Built using a number of heavy-duty features as standard, the McHale R62-72 rake is equipped with 11 tine arms per rotor. The rotor bogie runs on 4 wheels to allow for smooth ground adaptation over various ground conditions.

STANDARD FEATURES

- Hydraulic Width Adjustment
- Tine Arm Cam Adjustment
- Rotor Height Adjustment
- Individual Rotor Lift

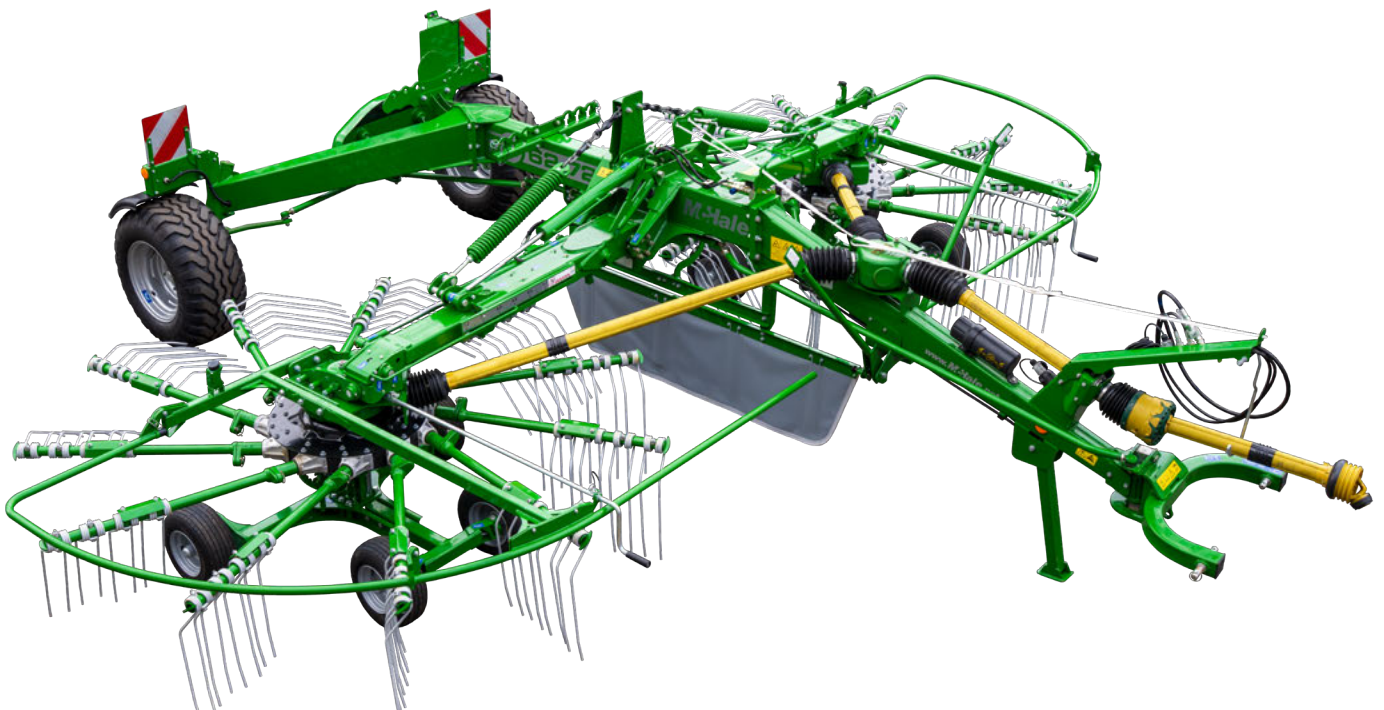
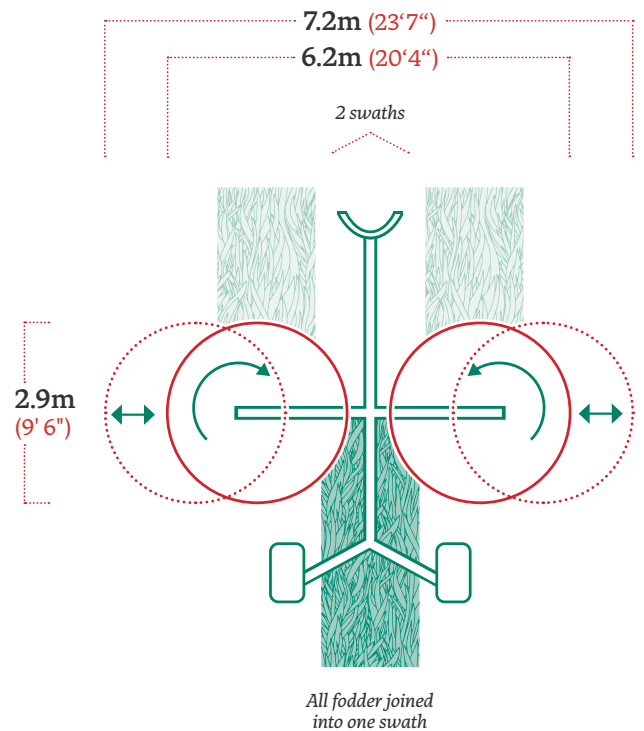

01 WORKING WIDTH
6.2m - 7.2m (20' 4" - 23' 7")

02 SWATH GATHERING
2 Swaths*

03 ROTOR DIAMETER
2.9m (9' 6")

04 TINE ARMS PER ROTOR
11

05 NO. OF ROTOR WHEELS
4

06 HECTARES PER HOUR
5

*Based on swaths from a 3m mower

R 68-78

The **MCHALE R68-78 CENTRE DELIVERY RAKE** is a high output rake with a working width of 6.8m (22' 4") to 7.8m (25' 7"). The McHale R68-78 rake can gather three, 3m swaths into one when raking mowed crop and also has the ability to form a uniform swath from crop which is left fully spread after mowing.

Like the R62-72, the McHale R68-78 rake is fitted with a number of high output features as standard, such as in-cab width adjustment, pivoting headstock, steering axle and a rotor mounted on a 6-wheel bogie which is equipped with 13 tine arms.

STANDARD FEATURES

- Hydraulic Width Adjustment
- Tine Arm Cam Adjustment
- Rotor Height Adjustment
- Individual Rotor Lift

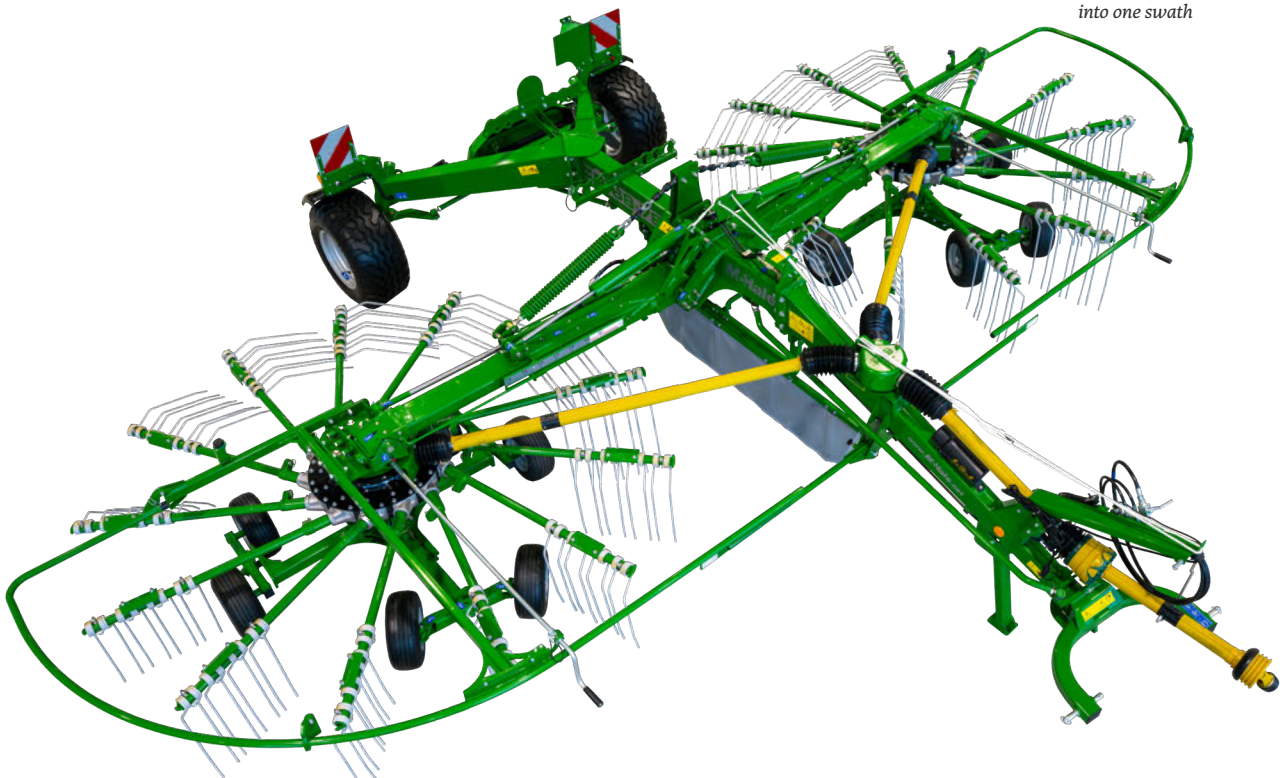
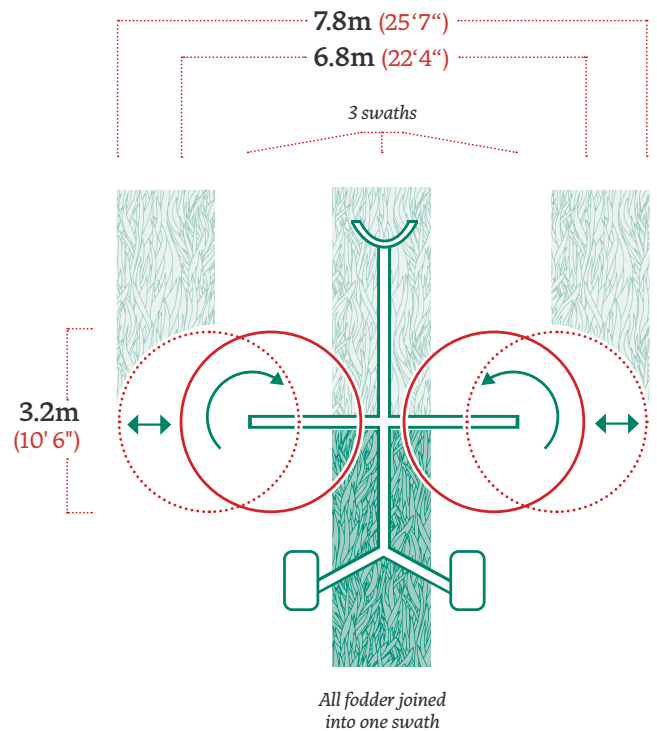

01 WORKING WIDTH
6.8m - 7.8m (22' 4" - 25' 7")

02 SWATH GATHERING
3 Swaths*

03 ROTOR DIAMETER
3.2m (10' 6")

04 TINE ARMS PER ROTOR
13

05 NO. OF ROTOR WHEELS
6

06 HECTARES PER HOUR
6

*Based on swaths from a 3m mower

R 80-90

The **MCHALE R80-90 CENTRE DELIVERY RAKE** is the largest rake in the range with a working width of 8.0m (26' 3") to 9.0m (29' 6"). The McHale R80-90 rake can gather four, 3m swaths into one when raking mowed crop and also has the ability to form a uniform swath from crop which is left fully spread after mowing.

Like the smaller models in the range, the McHale R80-90 rake is fitted with a number of high output features as standard, such as in-cab width adjustment, pivoting headstock, steering axle and a 3.8m rotor mounted on a 6-wheel bogie which is equipped with 13 tine arms.

STANDARD FEATURES

- Hydraulic Width Adjustment
- Tine Arm Cam Adjustment
- Rotor Height Adjustment
- Individual Rotor Lift

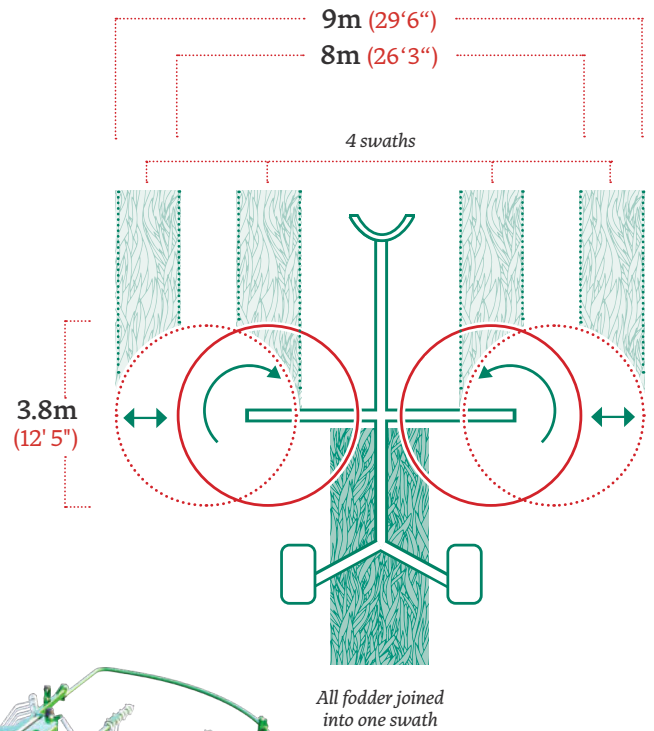

01 WORKING WIDTH
8m - 9m (26'3" - 29'6")

02 SWATH GATHERING
4 Swaths*

03 ROTOR DIAMETER
3.8m (12' 5")

04 TINE ARMS PER ROTOR
13

05 NO. OF ROTOR WHEELS
6

06 HECTARES PER HOUR
8

*Based on swaths from a 3m mower

R 62-72

R 68-78

R 80-90

THE MCHALE R RANGE of rakes have been tested in some of the world's most difficult conditions, delivering a strong and robust machine, which is efficient and reliable in all terrain. The McHale rakes are ideal machines for those who wish to obtain the best quality fodder, by delivering an aerated swath.

01 McHale Heavy-Duty Design

Through innovative design McHale has delivered a high-quality, heavy-duty range of rakes. These strong and robust machines are efficient and reliable in all crops and terrain.

02 Mudguards, Lights & Marker Boards

For operators and road user's safety, all McHale rakes are fitted with mudguards, road legal lights and reflective marker boards as standard.

03 Low Maintenance Steering System

McHale rakes feature a simple and low maintenance steering system as standard which enables the operator to master the tightest of turns while also providing excellent road stability.

04 Removable Tine Arms

All tine arms are removable for transport purposes or for ease of storage in low buildings.

05 Tine End Retainers

These ensure that if a tine does break, it will remain on the tine arm and will not fall into the swath.

06 Rotor Bogie

All McHale R62-72 rakes are equipped with a 4-wheel rotor bogie chassis while all R68-78 & R80-90 rakes are fitted with a 6-wheel rotor bogie chassis.

13 Tyres

All McHale rakes are equipped with wide 380/55-17 wide tyres as standard providing excellent stability on the road while minimising ground compaction in the field.

16 Rotor Height Adjustment

The working height of the tines are easily adjusted using the crank handles. Each rotor has a height indicator between the rotor and bogie chassis to ensure a correct and even setting.

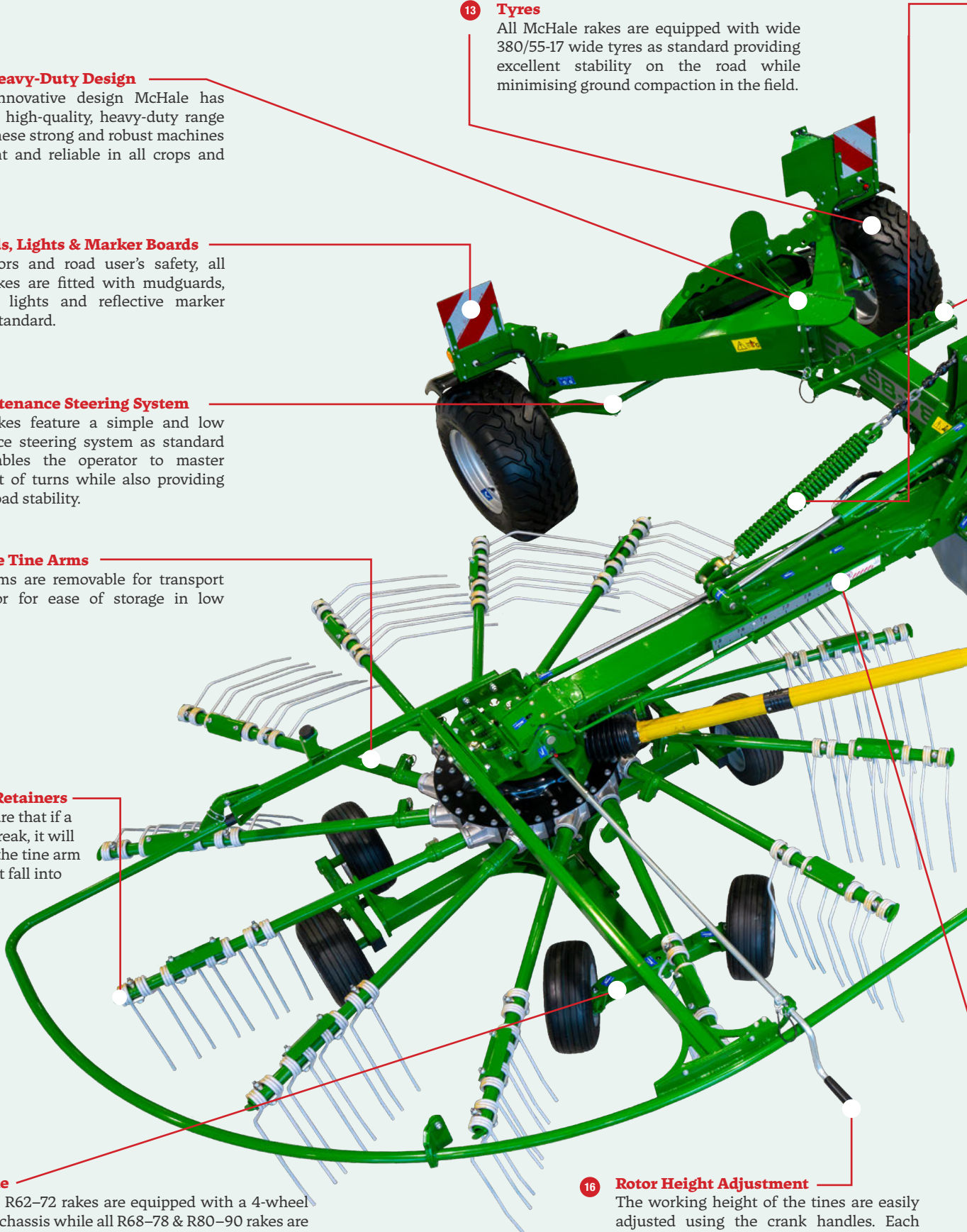

STANDARD FEATURES

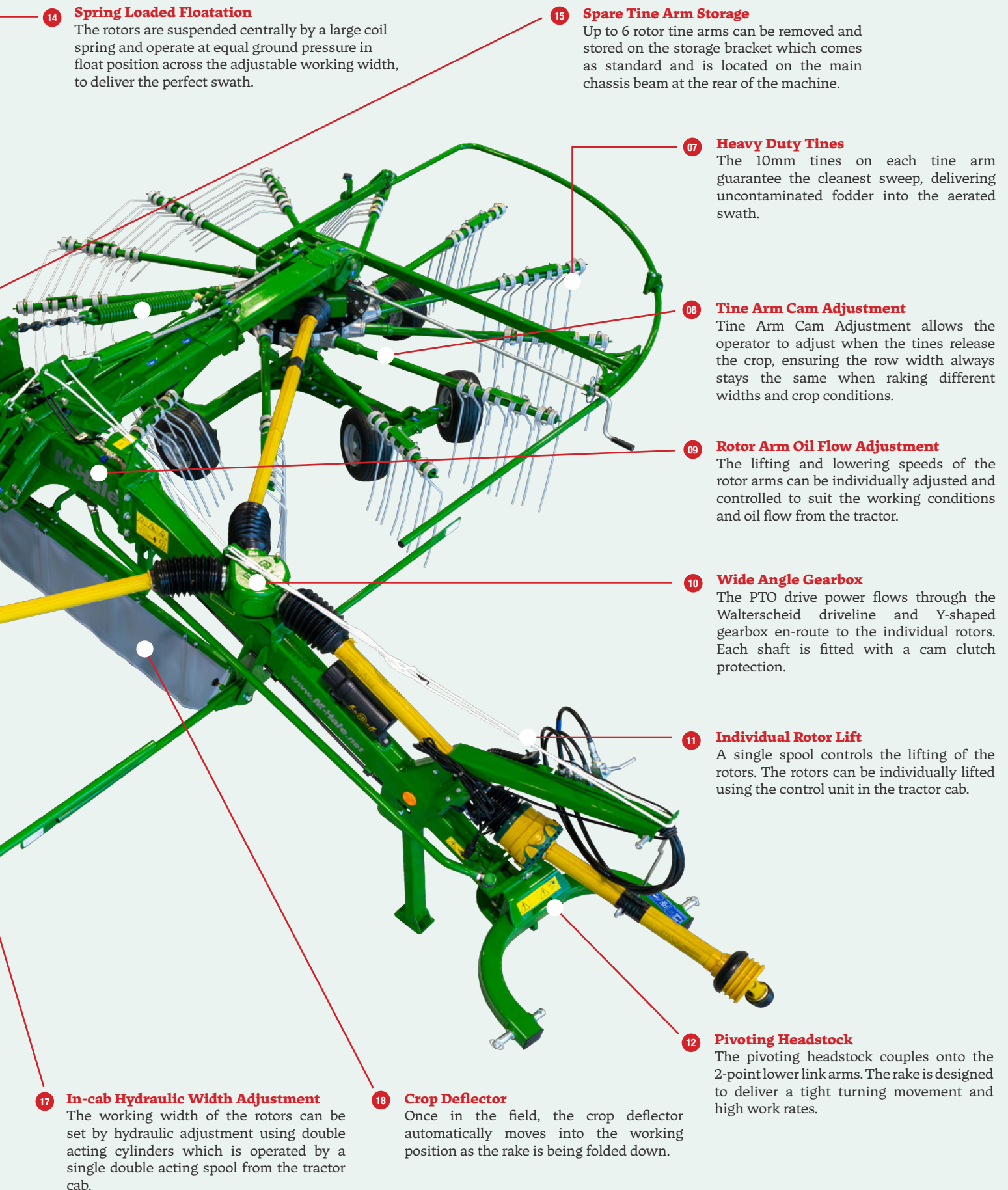

14 Spring Loaded Floatation

The rotors are suspended centrally by a large coil spring and operate at equal ground pressure in float position across the adjustable working width, to deliver the perfect swath.

15 Spare Tine Arm Storage

Up to 6 rotor tine arms can be removed and stored on the storage bracket which comes as standard and is located on the main chassis beam at the rear of the machine.

07 Heavy Duty Tines

The 10mm tines on each tine arm guarantee the cleanest sweep, delivering uncontaminated fodder into the aerated swath.

08 Tine Arm Cam Adjustment

Tine Arm Cam Adjustment allows the operator to adjust when the tines release the crop, ensuring the row width always stays the same when raking different widths and crop conditions.

09 Rotor Arm Oil Flow Adjustment

The lifting and lowering speeds of the rotor arms can be individually adjusted and controlled to suit the working conditions and oil flow from the tractor.

10 Wide Angle Gearbox

The PTO drive power flows through the Walterscheid driveline and Y-shaped gearbox en-route to the individual rotors. Each shaft is fitted with a cam clutch protection.

11 Individual Rotor Lift

A single spool controls the lifting of the rotors. The rotors can be individually lifted using the control unit in the tractor cab.

17 In-cab Hydraulic Width Adjustment

The working width of the rotors can be set by hydraulic adjustment using double acting cylinders which is operated by a single double acting spool from the tractor cab.

18 Crop Deflector

Once in the field, the crop deflector automatically moves into the working position as the rake is being folded down.

12 Pivoting Headstock

The pivoting headstock couples onto the 2-point lower link arms. The rake is designed to deliver a tight turning movement and high work rates.





McHale

McHale.net

PIVOTING HEADSTOCK

All McHale rakes are equipped with a pivoting headstock for an enhanced movement range of up to 80°, allowing easy navigation of difficult turns.

The headstock also has a transverse range of movement for working on uneven terrain.

The headstock is fitted with Cat II linkage mounts for easy attachment by the operator to various size tractors.



DRIVELINE



The McHale rake range is fitted with a wide-angle Y-Shaped drive line which is positioned on top of the chassis. Power is transmitted through heavy-duty tubing using Walterscheid drive shafts.

The drive shaft covers allow for easy and simple access to all greasing points without the need for any untidy anti-rotation chains on the shaft guards.

The use of these guards' results in improved operator safety by delivering guards with a longer service life.

HEAVY DUTY DESIGN

The innovative engineering on all McHale centre delivery rakes is based on a high-quality, heavy-duty design.

Following testing in some of the world's most difficult conditions, a robust and durable chassis design ensures efficient and reliable operation in all types of terrain.



VARIOUS ADJUSTMENTS



HYDRAULIC / IN-CAB WORKING WIDTH ADJUSTMENT

All McHale rakes come equipped with in-cab working width adjustment as standard. Depending on the model size, each rake offers a number of different working widths to suit various conditions. The variable working width is adjusted hydraulically using a spool in the tractor cab.



TINE ARM CAM ADJUSTMENT

Both rotors are fitted with Tine Arm Cam Adjustment to allow the speed at which the crop is distributed to the row to be adjusted. The cam angle for the tine arms can be simply adjusted to cater for all working widths and crops. Operators can choose from 1-8 positions to determine when the crop is released to the swath.

ROTOR HEIGHT ADJUSTMENT

All McHale rakes come with Rotor Height Adjustment as standard, ensuring a clean delivery of crop to the swath. By adjusting the height of the rotors, the operator can reduce soil contamination in the swath. Using easily adjustable winding handles on each rotor, the working height of the rotor tines can be altered. A rotor height indicator allows the operator to select a height from the 1-5 scale for accurate height adjustment on both rotors.



ROTORS

ROTOR BOGIES

For superior floatation, all McHale rakes are designed to follow the ground, providing the tines with a clean sweep of forage to the swath. The bogies are specifically engineered to have a wide footprint under the rotor for improved ground following and tine protection.

The McHale R62-72 is equipped with a 4-wheel rotor bogie. The R68-78 & R80-90 machines are fitted with a 6-wheel rotor bogie that allows for good ground adaptation and smooth running. The front wheels on both machines possess independent steering and the rear axles can be adjusted in height to alter the rotor inclination in varying ground conditions. A single rear axle is fitted to the rotor bogie of the R62-72 while the larger models run on a tandem axle.



ROTOR FLOATATION

Clean quality raking is achieved through the ability of the rotor to follow the ground. All McHale rakes are designed in a manner to allow the rotor to float in a forward to back and left to right movement of 9 degrees.

The movement of the rotor arm allows for good ground adaptation and smooth running to ensure a clean raked surface.

A large suspension spring controls the pressure of the rotor when on the ground. The spring has a greater range of adjustment which, if needed, make the rotors very light to gather clean forage to the swath.



ROTOR CAM TRACK UNIT

The rotors on all McHale rakes are controlled by a smooth-running cam track. The grease filled cam track is a sealed unit providing a longer life and uses two high quality bearings on each tine arm. These bearings are specially designed and sealed in order to reduce wear. If required, the rotor arms can be easily replaced by removing just three bolts.



INDIVIDUAL ROTOR LIFT

All McHale rakes are equipped with Individual Rotor Lift as standard which is controlled using a single acting spool and in cab control box.

By simply toggling left or right, along with activating the tractor's hydraulic spool for lifting and lowering the rotors, the operator can raise/lower each rotor individually.

When the toggle switch is returned to the central position, both rotors can be lifted and lowered together.

The control console can also be removed for safe keeping when not in use.

TINES

HEAVY DUTY TINES



The cranked tines on each tine arm guarantee the cleanest sweep, delivering uncontaminated fodder into the aerated swath.

All tines have a diameter of 10mm and also feature three coils, ensuring an easy flow of crop is delivered to the swath while remaining gentle on the ground.

TINE SAVERS & DEFLECTOR PLATES

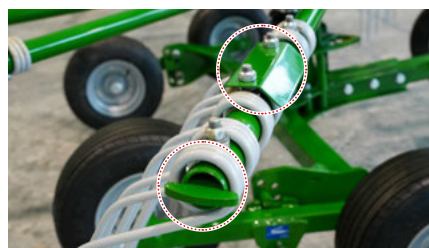

In order to prevent damage to your baler or harvester, all McHale rakes are equipped with Tine Savers. These ensure that if a tine does break, it will remain on the tine arm and will not fall into the swath.

Tine Deflector Plates are also fitted to all tine arms to deflect tines from coming into contact with the neighbouring tine arm.

DETACHABLE TINE ARMS

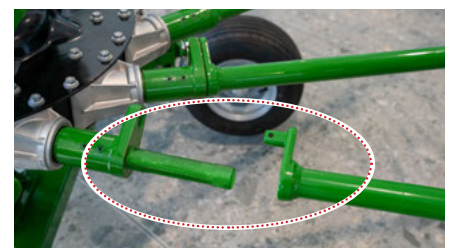

For operator convenience, all McHale rakes are fitted with easily removable tine arms. The profile of the tine arm is designed with a simple and positive holder which prevents twisting and bending.

The R62-72 is equipped with 11 tine arms while the R68-78 & R80-90 are fitted with 13 tine arms. Each machine has the ability to store 6 tine arms on the machine chassis.



LOW MAINTENANCE STEERING SYSTEM

The steering system on all McHale rakes is simple, effective and requires low maintenance from the operator.

Connected to the headstock of the machine, this steering system follows perfectly behind the tractor when in transport and during field operation to leave a neat swath on corners or bends. It also allows for even the tightest of gateways to be easily navigated upon entry or exit of the field.

ROAD TRANSPORT

For safe transportation on the road, the rotors fold up and move down into the locking position delivering a transport height under 4m. The width of all rakes is under 3m making the machine easily manoeuvrable even on narrow lanes.

For increased safety, all rakes come fitted with mudguards, reflective marker boards and road legal lights as standard.





OPTIONAL SPARE ROTOR BOGIE WHEEL

If required, all rakes in the centre delivery rake range can be equipped with a spare wheel for the rotor bogie as an optional extra.

This option is conveniently stored on the main chassis of the machine and can be quickly and easily released for replacing on the rotor bogie if required.



CENTRE DELIVERY RAKE RANGE TECHNICAL TABLE

			
DIMENSIONS & WEIGHT			
Transport Length	6.1m (20' 1")	6.1m (20' 1")	6.5m (21' 4")
Transport Width	2.85m (9' 4")	2.85m (9' 4")	3m (9' 10")
Transport Height	3.65m (11' 11")	3.91m (12' 9")	3.65m (12') *
Weight	1,900 kg (4,189 lbs)	2,100 kg (4,630 lbs)	2,635 kg (5,805 lbs)
MACHINE SPECIFICATIONS			
3 Metre Swath Gathering **	2 Swaths	3 Swaths	4 Swaths
Swath Width	0.8m – 1.6m / (2' 7" – 5' 3")	0.9m – 1.8m / (2' 11" – 5' 11")	0.8m – 2m / (2' 7" – 6' 7")
Incab Width Adjustment	Standard	Standard	Standard
Incab Adjustable Working Width	6.2m – 7.2m / (20' 4" – 23' 7")	6.8m – 7.8m / (22' 4" – 25' 7")	8m – 9m / (26' 3" – 29' 6")
Rotor Height Adjustment	Standard	Standard	Standard
Tine Arm Cam Adjustment	Standard	Standard	Standard
Number of Rotors / Wheels Per Rotor	2 rotors / 4 wheels per rotor	2 rotors / 6 wheels per rotor	2 rotors / 6 wheels per rotor
Rotor Diameter	2.9m (9' 6")	3.2m (10' 6")	3.8m (12' 5")
Individual Rotor Lift	Standard	Standard	Standard
Number of Tine Arms	11	13	13
Number of Tines / Per Arm	4	4	4
Tine Diameter	10mm (3 Coil)	10mm (3 Coil)	10mm (3 Coil)
Removable Tine Arms	Standard	Standard	Standard
Tine Arm Storage	6 x Tine Arms	6 x Tine Arms	6 x Tine Arms
Axle & Chassis Tyres	6 Stud – 380/55-17	6 Stud – 380/55-17	6 Stud – 380/55-17
Number of Rotor Tyres & Tyre Size	8 Tyres - 170/60-8	12 Tyres - 170/60-8	12 Tyres - 170/60-8
TRACTOR ATTACHMENT			
Minimum Power Requirement	45kW (61hp)	55kW (75hp)	67kW (90hp)
Mounting Category / Type	2 Point Linkage - Cat II	2 Point Linkage - Cat II	2 Point Linkage - Cat II
PTO Driveline	540rpm – Y Gearbox	540rpm – Y Gearbox	540rpm – Y Gearbox
Hydraulic Requirements	1 x Single Acting with Float / 1 x Double Acting	1 x Single Acting with Float / 1 x Double Acting	1 x Single Acting with Float / 1 x Double Acting
Greasing	Grease Nipples	Grease Nipples	Grease Nipples
Minimum Flow Rate	20 l/min (4.54 gal/min) @180 bar (2,610psi)	20 l/min (4.54 gal/min) @180 bar (2,610psi)	20 l/min (4.54 gal/min) @180 bar (2,610psi)
OPTIONAL EQUIPMENT			
Spare Rotor Wheel	Optional	Optional	Optional
Wheel Weights			Optional

*tine arms removed

**Based on swaths from a 3m mower





M-Hale

Ballinrobe,
Co. Mayo,
Ireland
F31 K138

T. 353 (0) 94 95 20300
F. 353 (0) 94 95 20356
E. sales@mchale.net

WWW.MCHALE.NET

Distributed by:

DISCLAIMER: This literature is designed for worldwide circulation. Due to a continuing policy of product improvement, we reserve the right to alter specifications and constructions without notice. As machines are exported to many different countries, general information, pictures and descriptions are provided; these should be taken as approximate and may include optional equipment that is not part of the standard specification. Please consult your local dealer or distributor for further information.